

Low-Power, Slew-Rate-Limited RS-485/RS-422 Transceiver

DESCRIPTION

The MAX485 is low-power transceivers for RS-485 and RS-422 communication. The IC contains one driver and one receiver. The driver slew rates of the MAX485 is not limited, allowing them to transmit up to 2.5Mbps. These transceivers draw between 120 μ A and 500 μ A of supply current when unloaded or fully loaded with disabled drivers. All parts operate from a single 5V supply. Drivers are short-circuit current limited and are protected against excessive power dissipation by thermal shutdown circuitry that places the driver outputs into a high-impedance state. The receiver input has a fail-safe feature that guarantees a logic-high output if the input is open circuit. The MAX485 is designed for half-duplex applications.

PIN CONFIGURATION

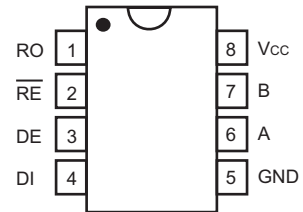

D OR P PACKAGE

(Top View)

FEATURES

- Low Quiescent Current: 300 μ A
- -7V to +12V Common-Mode Input Voltage Range
- Three-State Outputs
- 30ns Propagation Delays, 5ns Skew
- Operate from a Single 5V Supply
- Allows up to 32 Transceivers on the Bus
- Data rate: 2.5 Mbps
- Current-Limiting and Thermal Shutdown for Driver Overload Protection
- The transmitter outputs and receiver inputs are protected to ± 15 kV Air ESD

APPLICATION

- Low-Power RS-485 Transceivers
- Low-Power RS-422 Transceivers
- Level Translators
- Transceivers for EMI-Sensitive Applications
- Industrial-Control Local Area Networks

ORDERING INFORMATION

Temperature Range	Package		Orderable Device	Package Qty
0°C to +70°C	SOP8L	Pb-Free	MAX485D	100Units/Tube
	DIP8L		MAX485DR	3000Units/R&T
			MAX485P	25Units/Tube



PIN DESCRIPTION

No.	Name	Function
1	RO	Receive output: if $A > B$ by 200mV, RO will be high; if $A < B$ by 200mV, RO will be low.
2	\overline{RE}	Receiver Output Enable. RO is enabled when \overline{RE} is low; RO is high impedance when \overline{RE} is high.
3	DE	Driver Output Enable. The driver outputs are enabled when DE is high. They are high impedance when DE is low. If the driver outputs are enabled, the parts function as line drivers. While they are high impedance, they function as line receivers if \overline{RE} is low.
4	DI	Driver input. A low on DI forces output A low and output B high. Similarly, a high on DI forces output A high and output B low.
5	GND	Ground
6	A	Driver Output and Receiver differential input.
7	B	Driver Output and Receiver differential input.
8	V _{CC}	Positive Supply: $4.75V \leq V_{CC} \leq 5.25V$

FUNCTION TABLE

Transmitting					Receiving			
Inputs			Outputs		Inputs			Outputs
\overline{RE}	DE	DI	A	B	\overline{RE}	DE	A-B	RO
X	1	1	1	0	0	0	+0.2V	1
X	1	0	0	1	0	0	-0.2V	0
0	0	X	Z	Z	0	0	open	1
1	0	X	Z	Z	1	0	X	Z

Z=high impedance
X=don't care

FUNCTIONAL DIAGRAM

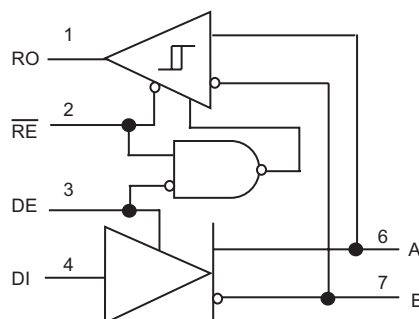

Figure 1. Functional Diagram

ABSOLUTE MAXIMUM RATINGS

Parameter	Symbol	Value	Unit
Supply Voltage	V _{CC}	12V	V
Control Input Voltage	V _{CI}	-0.5 to (V _{CC} +0.5)	V
Driver Input Voltage	DI	-0.5 to (V _{CC} +0.5)	V
Driver Output Voltage (A, B)	DO	-8 to +12.5	V
Receiver Input Voltage (A, B)	V _{RIV}	-8 to +12.5	V
Receiver Output Voltage	RO	-0.5 to (V _{CC} +0.5)	V
8-Pin Plastic DIP Continuous Power Dissipation (derating 9.09mW/°C above +70°C)	P _{DIP}	727	mW
8-Pin SOP Continuous Power Dissipation (derating 5.88mW/°C above +70°C)	P _{SOP}	471	mW
Operating Temperature Range	T _A	0 to +70	°C
Storage Temperature Range	T _{STG}	-65 to +160	°C
Lead Temperature, 10 sec	T _L	+300	°C

DC ELECTRICAL CHARACTERISTICS

(V_{CC} = 5V ±5%, T_A = T_{MIN} to T_{MAX}, unless otherwise noted.) (Notes 1, 2)

Parameter	Symbol	Test Conditions	Min	Typ	Max	Unit
Differential Driver Output (no load)	V _{OD1}				5	V
Differential Driver Output (with load)	V _{OD2}	R = 50Ω (RS-422)	2			V
		R = 27Ω (RS-485), Figure 3	1.5		5	
Change in Magnitude of Driver Differential Output Voltage for Complementary Output States	ΔV _{OD}	R = 27Ω or 50Ω, Figure 3			0.2	V
Driver Common-Mode Output Voltage	V _{OC}	R = 27Ω or 50Ω, Figure 3			3	V
Change in Magnitude of Driver Common-Mode Output Voltage for Complementary Output States	ΔV _{OD}	R = 27Ω or 50Ω, Figure 3			0.2	V
Input High Voltage	V _{IH}	DE, DI, \overline{RE}	2.0			
Input Low Voltage	V _{IL}	DE, DI, \overline{RE}			0.8	V
Input Current	I _{INI}	DE, DI, \overline{RE}			±2	μA



DC ELECTRICAL CHARACTERISTICS(CONTINUED)

Parameter	Symbol	Test Conditions	Min	Typ	Max	Unit
Input Current (A, B)	I_{IN2}	DE = 0V; V _{CC} = 0V or 5.25V	V _{IN} = 12V		1.0	mA
			V _{IN} = -7V		-0.8	
Receiver Differential Threshold Voltage	V _{TH}	-7V ≤ V _{CM} ≤ 12V	-0.2		0.2	V
Receiver Input Hysteresis	ΔV _{TH}	V _{CM} = 0V		70		mV
Receiver Output High Voltage	V _{OH}	I _O = -4mA, V _{ID} = 200mV	3.5			V
Receiver Output Low Voltage	V _{OL}	I _O = 4mA, V _{ID} = -200mV			0.4	V
Three-State (high impedance) Output Current at Receiver	I _{OZR}	0.4V ≤ V _O ≤ 2.4V			±1	μA
Receiver Input Resistance	R _{IN}	-7V ≤ V _{CM} ≤ 12V	12			kΩ
No-Load Supply Current (Note 3)	I _{CC}	DE = V _{CC} , RE = 0V or V _{CC}		500	900	μA
		DE = 0V, RE = 0V or V _{CC}		300	500	
Driver Short-Circuit Current, V _O = High	I _{OSD1}	-7V ≤ V _O ≤ 12V	35		250	mA
Driver Short-Circuit Current, V _O = Low	I _{OSD2}	-7V ≤ V _O ≤ 12V	35		250	mA
Receiver Short-Circuit Current	I _{OSR}	0V ≤ V _O ≤ V _{CC}	7		95	mA

SWITCHING CHARACTERISTICS

(V_{CC} = 5V ±5%, T_A = T_{MIN} to T_{MAX}, unless otherwise noted.) (Notes 1, 2)

Parameter	Symbol	Test Conditions	Min	Typ	Max	Unit
Driver Input to Output Propagation delay time	t _{PLH}	R _{DIFF} = 54Ω	10	30	60	ns
	t _{PHL}	C _{L1} = C _{L2} = 100pF	10	30	60	
Driver Output Skew	t _{SKEW}	R _{DIFF} = 54Ω C _{L1} = C _{L2} = 100pF	5	10	5	ns
Driver Enable to Output High	t _{ZH}	C _L = 100pF, S2 closed	40	70	40	ns
Driver Enable to Output Low	t _{ZL}	C _L = 100pF, S1 closed	40	70	40	ns
Driver Disable Time from Low	t _{LZ}	C _L = 15pF, S1 closed	40	70	40	ns
Driver Disable Time from High	t _{HZ}	C _L = 15pF, S2 closed	40	70	40	ns
t _{PLH} - t _{PHL} Differential Receiver Skew	t _{SKD}	R _{DIFF} = 54Ω C _{L1} = C _{L2} = 100pF	13		13	ns
Receiver Enable to Output Low	t _{ZL}	C _{RL} = 15pF, S1 closed	20	50	20	ns



SWITCHING CHARACTERISTICS(CONTINUED)

Parameter	Symbol	Test Conditions	Min	Typ	Max	Unit
Receiver Enable to Output High	t_{ZH}	$C_{RL} = 15\text{pF}$, S2 closed	20	50	20	ns
Receiver Disable Time from Low	t_{LZ}	$C_{RL} = 15\text{pF}$, S1 closed	20	50	20	ns
Receiver Disable Time from High	t_{HZ}	$C_{RL} = 15\text{pF}$, S2 closed	20	50	20	ns
Maximum Data Rate	f_{MAX}		2.5			Mbps

- Notes**
- 1: All currents into device pins are positive; all currents out of device pins are negative. All voltages are referenced to device ground unless otherwise specified.
 - 2: All typical specification are given for $V_{CC} = 5\text{V}$ and $T_A = +25^\circ\text{C}$
 - 3: Supply current specification is valid for loaded transmitters when $DE = 0\text{V}$.

TYPICAL APPLICATION CIRCUIT

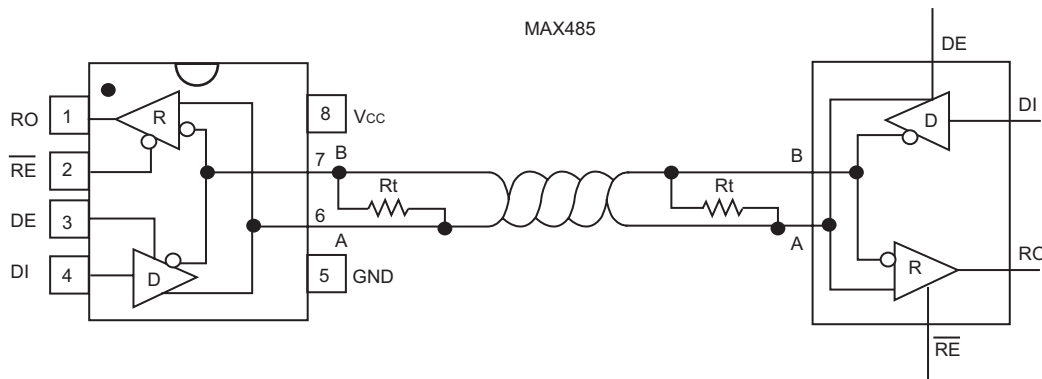

Figure 2. Typical Circuit

TEST CIRCUITS

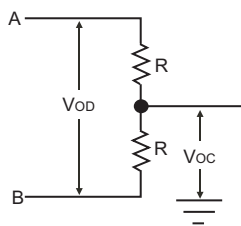

Figure 3. Driver DC Test Load

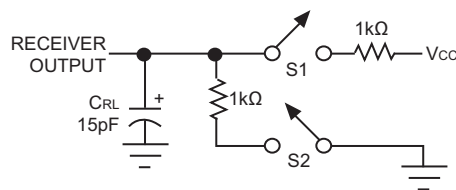

Figure 4. Receiver Timing Test Load

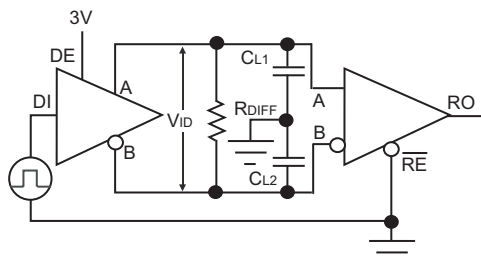

Figure 5. Driver / Receiver Timing Test Circuit

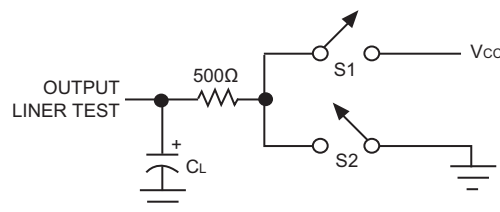

Figure 6. Driver Timing Test Load

Operation timing diagrams

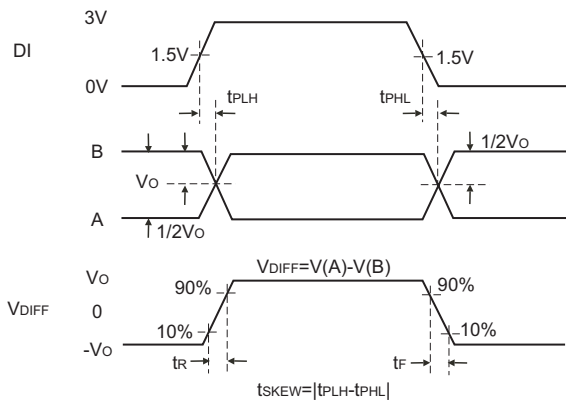

Figure 7. Driver transmission Delay timing

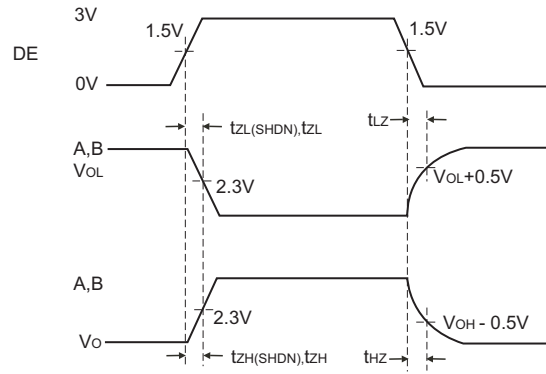

Figure 8. Driver enable and disable timing

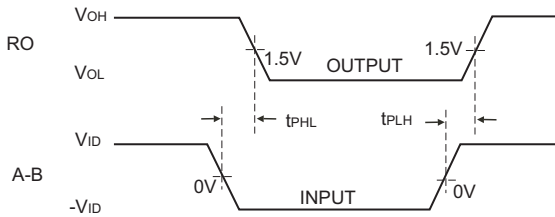

Figure 9. Receiver transmission Delay timing

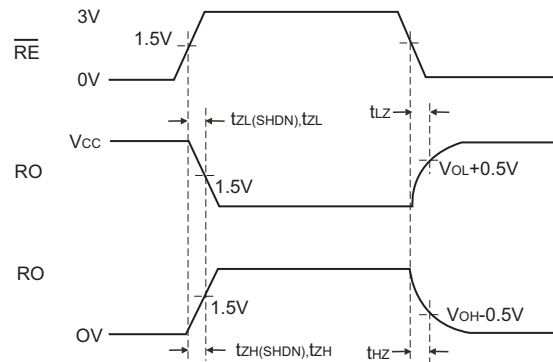
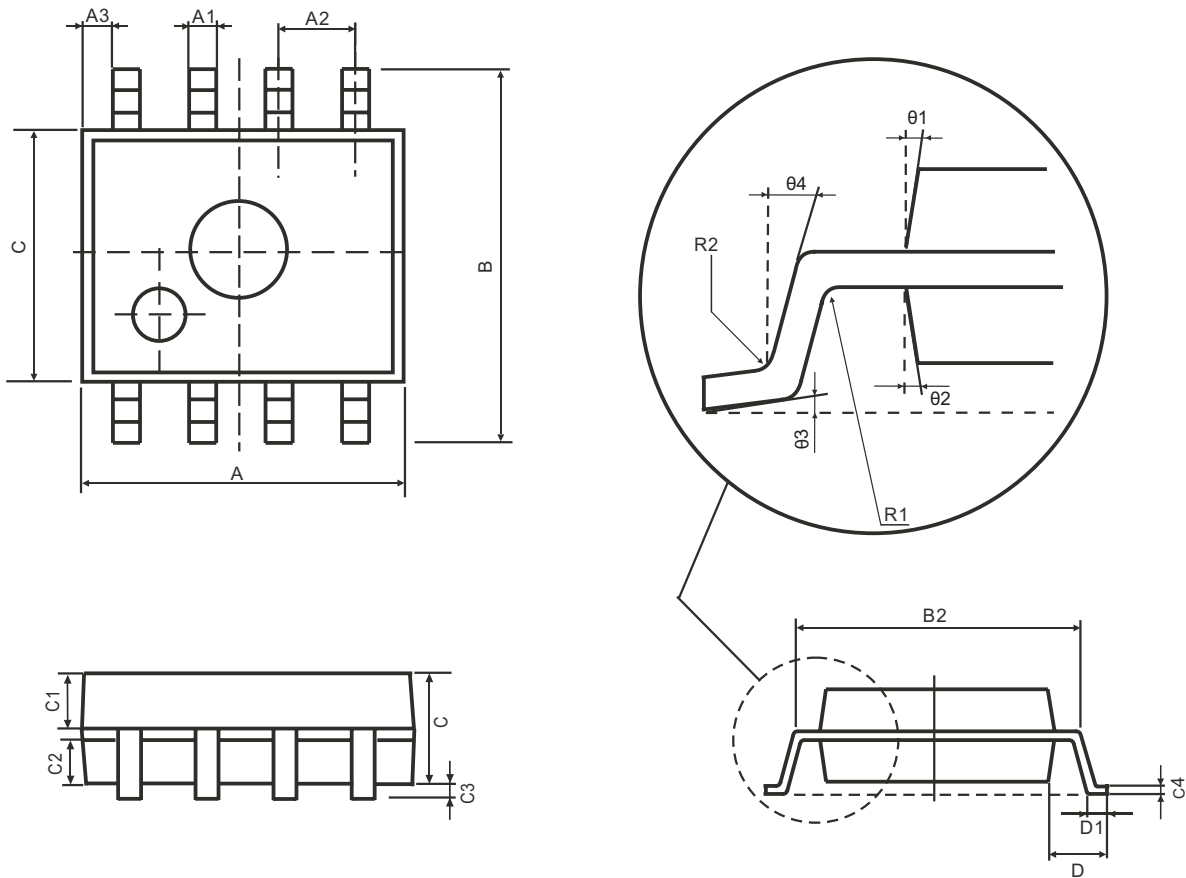

Figure 10. Receiver enable and disable timing

PHYSICAL DIMENSIONS SOP8L



Symbol	Dimension(mm)		Symbol	Dimension(mm)	
	Min	Max		Min	Max
A	4.95	5.15	C3	0.05	0.20
A1	0.37	0.47	C4	0.20(TYP)	
A2	1.27(TYP)		D	1.05(TYP)	
A3	0.41(TYP)		D1	0.40	0.60
B	5.80	6.20	R1	0.07(TYP)	
B1	3.80	4.00	R2	0.07(TYP)	
B2	5.0(TYP)		θ1	17°(TYP)	
C	1.30	1.50	θ2	13°(TYP)	
C1	0.55	0.65	θ3	4°(TYP)	
C2	0.55	0.65	θ4	12°(TYP)	



DIP8L

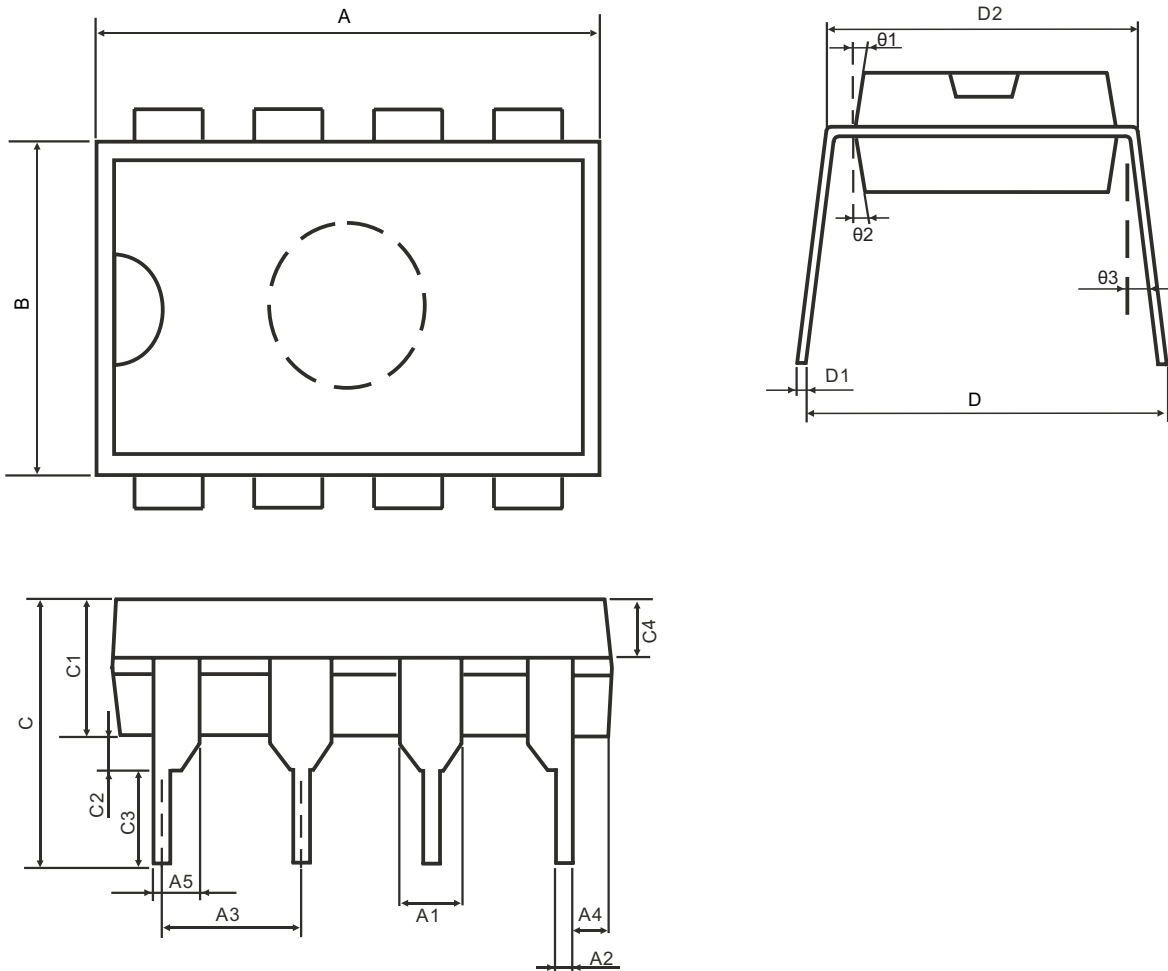

Symbol	Dimension(mm)		Symbol	Dimension(mm)	
	Min	Max		Min	Max
A	9.30	9.50	C2	0.5(TYP)	
A1	1.524(TYP)		C3	3.3(TYP)	
A2	0.39	0.53	C4	1.57(TYP)	
A3	2.54(TYP)		D	8.20	8.80
A4	0.66(TYP)		D1	0.20	0.35
A5	0.99(TYP)		D2	7.62	7.87
B	6.3	6.5	theta1	8°(TYP)	
C	7.20(TYP)		theta2	8°(TYP)	
C1	3.30	3.50	theta3	5°(TYP)	